

Caliber® Poly-Shield™ Series III

Installation Instructions Part No. 13401

HARDWARE CONTENTS:

Qty	Description	Qty	Description
2	Large Hair Pin	26	Black Plastic Rivet (6 extra)
12	#12 Phillips Screw	2	Ring Pin with Hair Pin
6	1/4" x 1-3/4" Round Head Screw	6	Nylon Lanyard (Black Plastic)
6	1/4" Lock Nut	3	Salt Shield Section (Plastic)
6	Snap Cap (Black Plastic)	2	Bent Pipe
6	Snap Washer (Clear Plastic)	1	Straight Pipe

TOOLS REQUIRED:

Straight Screwdriver
Tape Measure
Power Hand Drill
Drill Bits – 7/16", 1/4", 1/8", 17/64"
Wrench -7/16"
Pencil

READ ALL INSTRUCTIONS CAREFULLY PRIOR TO ASSEMBLY

- Step 1:** *Location A* - Using a 7/16" drill bit, drill hole 18.5" back from the front edge of the trailer and up 1" from the trailer deck. Repeat for opposite side.
- Step 2:** Insert each bent pipe into each end of the straight pipe. The sections of pipe will be fastened together in a later step. Insert the peg at the end of each leg of pipe into the holes at *Location A*. Insert a large hair pin into each peg, swing brace assembly towards rear of trailer and lay it down flat on the deck.
- Step 3:** *Location B*. Draw a line on the trailer deck 8" back from the front edge of the trailer. Place the two outer sections of the Poly-Shield on the trailer deck with them pushed outward against the sides of the trailer and the back edge of the shield on the line that was drawn.
- Step 4:** Screw the bottom of each outer section of Poly-Shield to the trailer deck, using two of the #12 Phillips screws in each section. (If you want your shield to be detachable, you can remove these screws after the shield is fully assembled.)
- Step 5:** Swing the brace assembly forward into the preformed channel at the top of the Poly-Shield. Slide the center section of brace pipe to the right or left to center it between the two outer sections of the Poly-Shield. You may need someone to hold the Poly-Shield sections and the brace together while complete the next step.
- Step 6:** *Location C*. Locate the hole in each corner of bent pipe. With a 1/4" drill bit, drill through the back of the shield by inserting the drill bit through the hole in the bent pipe. **IMPORTANT:** Make sure the bent pipes and the shield sections are tight against the sides of the trailer by applying slight outward pressure on them before drilling these two holes.
- Step 7:** Slide a clear snap washer onto a 1/4" screw and through the shield and pipe at both locations in the previous step. Install and tighten a lock nut onto both screws.
- Step 8:** *Location D*. Hold the shield tight to the pipe and use an 1/8" bit to pre-drill a hole through the front of the shield and pipe at both dimpled locations in the front of the shield. **HELPFUL HINT:** Go slow and be sure you are drilling perpendicular to the pipe, this will make drilling the hole on the curved surface easier.
- Step 9:** Now use a 1/4" bit and drill out the holes created in the previous step. Slide a 1/4" screw through a clear snap washer, shield and pipe at *Location D*. Install and tighten a lock nut onto both screws.
- Step 10:** Slide the center section of Poly-Shield over the top of the two outer sections.

Step 11: *Location F.* Using an 1/8" drill bit, drill through the Poly-Shield and brace pipe assembly 1" in from the outer edge of the center section of shield at the locations illustrated while holding all three sections of shield together with clamps or an extra helping hand. Be sure the shield sections line up well before drilling the holes.

Step 12: Now use a 1/4" bit and drill out the holes from the previous step. Slide a clear snap washer onto a 1/4" screw and through the shield and pipe at *Location F.* Install and tighten a lock nut onto both screws.

Step 13: Snap on all six black caps onto the clear washers on the front of the shield.

Step 14: Start at the top of the shield and drill through the shield at just 1 of the 14 dimple locations in the center section with a 17/64" drill bit.

Step 15: Insert a plastic rivet into the hole from previous step. **IMPORTANT:** Support the shield from the backside with a block of wood right next to the rivet or a block with a hole in it. Then tap the rivet pin lightly with hammer until it is flush with the head of the rivet. Repeat this process for each of the remaining dimple locations by completing one hole at a time.

NOTE: The rivets on the bottom of the shield do not have dimple marks and are only necessary to install if you plan on using the quick detach mounting. If so, complete them after **Step 20** by removing the shield from the trailer and drilling holes 1 1/2" in from the back edge of the shield.

Step 16: *Location E.* Using a 5/16" drill bit, drill through the trailer and shield 1" down from the top edge of the trailer's side rail and 1" toward the front of the trailer from the back edge of the shield. Use the ring pin to fasten the shield to the trailer as shown. Repeat for other side.

Step 17: Use a plastic lanyard and connect one end of it to the ring on the ring pin and the other end of the lanyard to the hair pin fastened to the ring pin. This will keep you from losing the hair pin in the snow.

Step 18: *Location G.* Using a 1/4" drill bit, drill a hole in the side pipe and a hole in the salt shield. Fasten one lanyard to the pipe by using a plastic rivet through the eyelet end of the lanyard and attach the other end of the lanyard to the hair pin for the side pipe. Fasten another lanyard to the shield by using a plastic rivet through the eyelet end of the lanyard and attach the other end of the lanyard to the ring on the ring pin. Repeat for other side.

WARNING: Both ring pins and all hair pins must be used when transporting the trailer with the Poly-Shield installed, whether you are permanently mounting the shield or using the quick-detach mounting method. Caliber is not responsible for the quality of the trailer deck and does not recommend relying only on the #12 screws to hold the Poly-Shield down to the trailer deck.

Step 19: For permanent mounting, use the remaining #12 Phillips screws to mount the bottom of the shield to the trailer deck. Permanent mounting will keep the shield tight to the trailer deck and minimize the amount of road debris that ends up on your trailer or cargo.

Step 20: For quick-detach mounting, remove all #12 Phillips screws used in **Step 4.** Then the shield can quickly be detached by removing the lynch pins and cotter pins. Quick-detach mounting allows for easy removal of the Poly-Shield for trailers where the snowmobiles can be driven off the front.

LIFETIME LIMITED WARRANTY

Caliber warrants this product to be free from defects in material and workmanship under use for the purpose it was intended. Caliber shall not be liable for damage or injury caused by defective materials or workmanship. Caliber may elect to repair or replace this product, but is the sole judge of any defects in their product. This warranty does not cover any labor costs to remove or reinstall this product and is in effect for one year from the original purchase date.

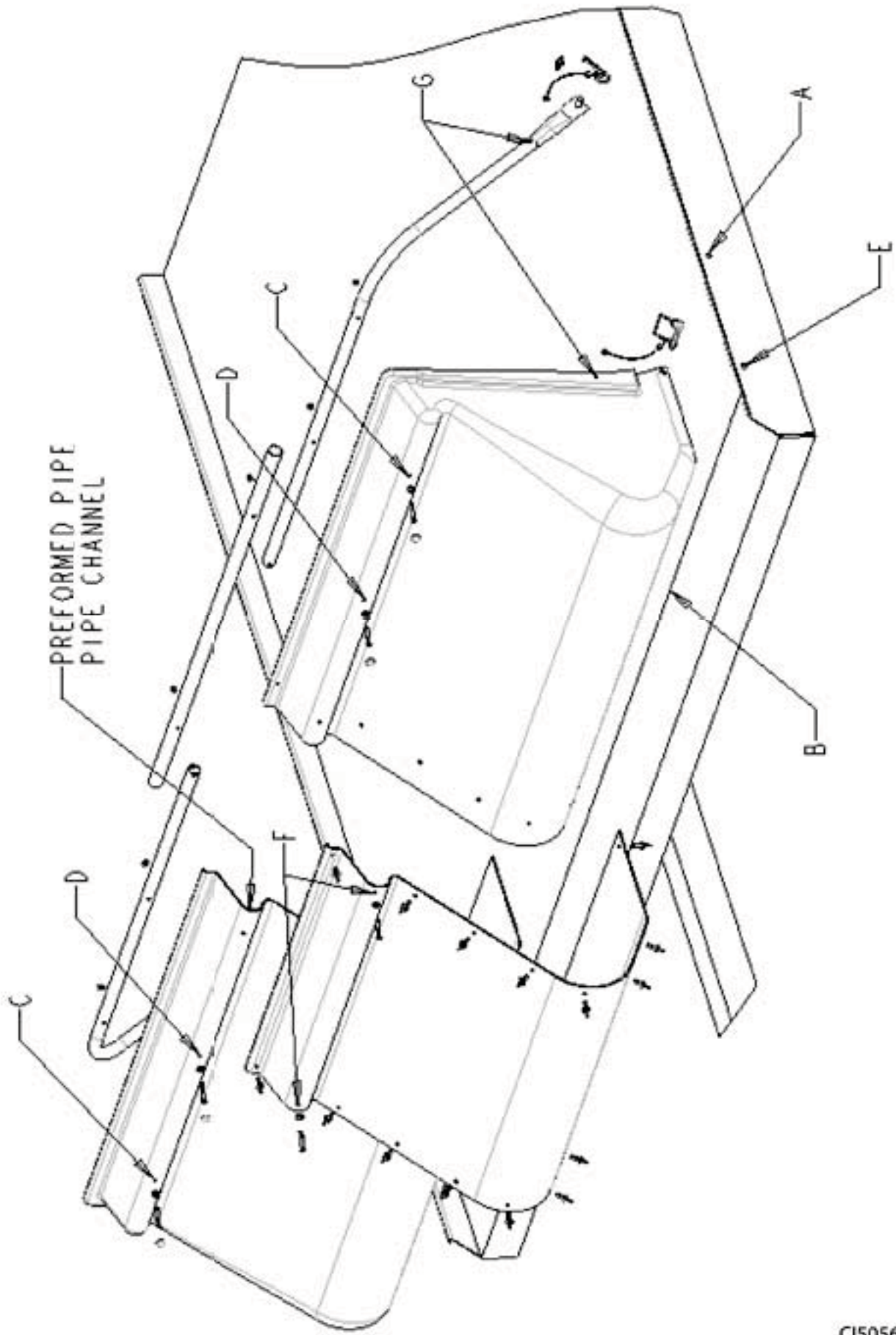

PREFORMED PIPE
PIPE CHANNEL

CI5056