

**IMPORTANT: READ THE FOLLOWING INFORMATION BEFORE OPERATING YOUR:**



**P/N 23007 / 23026** (set of two)

# LIGHT TRAILER STABILIZING JACK

FOR USE ON LIGHTWEIGHT TRAVEL TRAILERS AND TENT TRAILERS

## INSTALLATION AND OPERATING INSTRUCTIONS

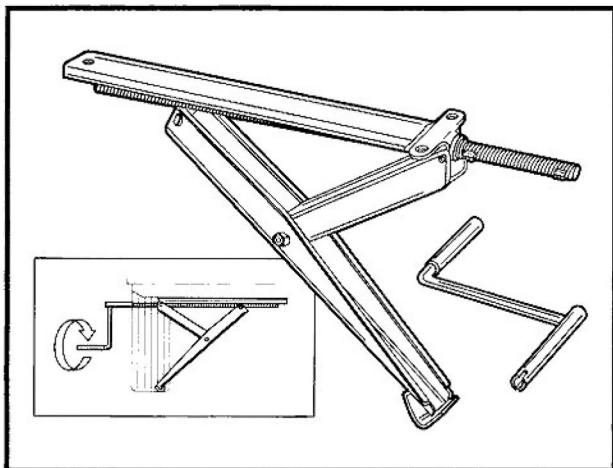

**THIS LIGHT TRAILER TYPE STABILIZING JACK IS DESIGNED FOR:**

**FINE LEVELING AND STABILIZING LIGHT-WEIGHT AND TENT TRAILERS WITH UP TO 14" OF CLEARANCE FROM FRAME TO GROUND.**

### SAFETY WARNINGS:

- **DO NOT** ATTEMPT TO USE THIS STABILIZING JACK FOR JACKING PURPOSES OR TO SUPPORT THE FULL WEIGHT OF THE TRAILER. USE ONLY THE CRANK HANDLE PROVIDED.
- **DO NOT** ATTEMPT TO USE THIS STABILIZING JACK FOR ANY PURPOSE OTHER THAN ITS INTENDED DESIGN.

## DETERMINING CORRECT MOUNTING LOCATION

WHEN SELECTING PLACEMENT FOR INSTALLATION...

- BE SURE THAT THERE IS ADEQUATE GROUND CLEARANCE.
- BE SURE THAT DRIVE SCREW IS ACCESSIBLE.
- PARK ON LEVEL GROUND

## ADDING A CROSS MEMBER

Lightweight Stabilizers are designed to mount to the trailer frame where the crossmember meets the main frame member. On some trailers the frame is enclosed with an underskin. Screws or rivets attaching the under skin to the trailer frame crossmembers will help locate the crossmembers.

**NOTE:** Using the criteria above "Determining correct mounting location" do the following:

- Find the closest existing crossmember
- If there is no crossmember at the desired location a crossmember must be added.

**If a crossmember must be added:** Use a piece of 2 x 2-1/4" angle iron or equivalent and weld flush with the trailer frame.

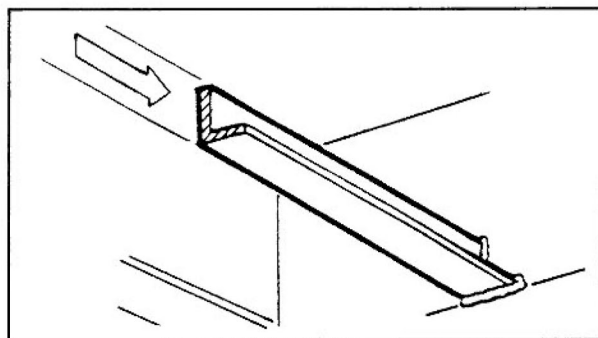

# INSTALLATION

Tools required: hammer, center punch, drill motor, 13/64" diameter drill bit, 3/8" socket and ratchet.

## MODEL 23025

**NOTE:** Park trailer on level ground. Prevent wheels from rolling by using tire chocks, landing gear, or tongue jack.

### BOLT-ON INSTALLATION

**STEP 1.** For each stabilizer, place the front mounting plate holes in the middle of the main trailer frame tube, position the rear of the jack so the mounting hole lines up with the crossmember. Crank the stabilizer open so it is secure against the ground and frame (Figure 1).

**STEP 2.** With the stabilizers in the desired locations, use the mounting plates as a template. Mark the mounting hole locations on the trailer frame with a center punch. Remove stabilizers. Drill (3 each) 13/64" holes in the trailer frame, two at the wide mounting plate location and one in the crossmember for the narrow mounting plate for each stabilizer (Figure 2).

**STEP 3.** Reposition the stabilizers and mount to the trailer frame using the 3/8" socket and ratchet with the self threading screws and lock washers.

**STEP 4.** Make sure stabilizers are cranked up before moving trailer.

### WELD-ON INSTALLATION

**STEP 1.** For each stabilizer, place the front mounting plate holes in the middle of the main trailer frame tube, position the rear of the jack so the mounting hole lines up with the crossmember. Crank the stabilizer open so it is secure against the ground and frame (Figure 1).

**STEP 2.** With stabilizers in desired location, clamp in place and weld mounting plates to trailer frame as shown in Figure 3.

**STEP 3.** Make sure stabilizers are cranked up before moving trailer.

### TENT TRAILER INSTALLATION

For each stabilizer, place the front mounting plate holes on the crossmember and the outside frame rail that form the corner of the tent trailer (See figure 4). Position the rear mounting hole of the stabilizer so it is in the middle of the main frame tube (Figure 4).

**NOTE:** The stabilizer must be positioned so the handle end of the drive screw does not extend beyond the side wall of the trailer.

For bolt-on installation see steps 2, 3 and 4 of bolt-on installation instructions, above.

For weld-on installation see steps 2 and 3 of weld-on installation, above.

## OPERATION

**STEP 1.** Park RV on level ground, prevent wheels from rolling by using tire chocks.

**STEP 2.** Level trailer fore and aft using tongue jack.

**STEP 3.** Check level gauge for low side of trailer, crank down stabilizers on low side first, bringing the trailer to a fine level position.

**STEP 4.** Crank down stabilizers on opposite side of trailer to insure maximum stability. Then re-snug stabilizers on low side of trailer if necessary.

**NOTE - BEFORE MOVING TRAILER:** Crank up stabilizers to fully closed position and tighten 1/4 turn to secure in travel position (this prevents stabilizers from working open due to road vibration.).

### MAINTENANCE

Use small amounts of WD-40 or similar lubricant on drive screw threads and bolt locations as required.

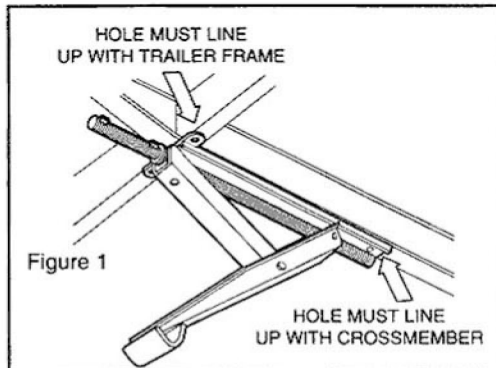

Figure 1

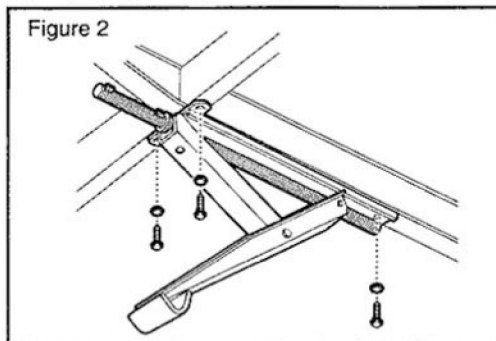

Figure 2

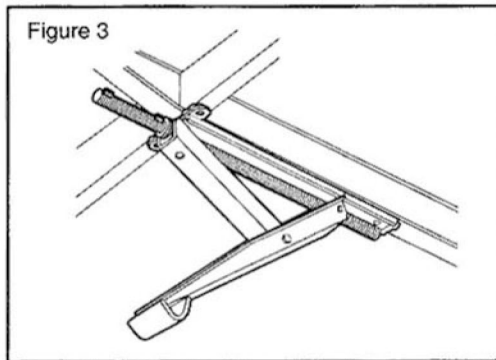

Figure 3

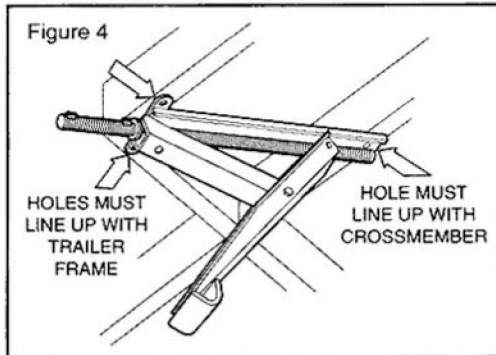

Figure 4

**BAL**  
RV PRODUCTS GROUP

For information or parts contact:  
BAL RV PRODUCTS  
A Division of Norco Industries Inc.,  
365 W. Victoria St., Compton, CA 90220  
(310) 639-4000 or (310) 636-1176

A DIVISION OF NORCO INDUSTRIES, INC.